

SF11 thru SF16

SUPER FAST RECTIFIER



**CHENG-YI
ELECTRONIC**



FEATURES

- High reliability
- Low leakage
- Low forward voltage
- High current capability
- Super fast switching speed
- High surge capability
- Good for switching mode circuit

MECHANICAL DATA

- Case: Molded plastic
- Epoxy: UL94V-0 rate flame retardant
- Lead: MIL-STD-202E method 208C quaranted
- Mounting position: Any
- Weigh: 0.33 grams

SUPER FAST RECTIFIER
VOLTAGE RANGE-50 to 400 Volts
CURRENT-1.0 Amperese

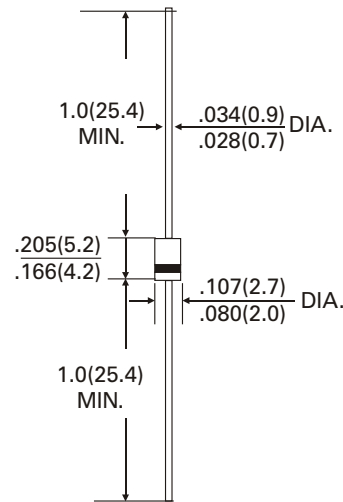

Dimensions in inches and (millimeters)

MAXIMUM RATINGS AND ELECTRICAL CHARACTERISTICS

Ratings at 25°C ambient temperature unless otherwise specified.

Single phase, half wave, 60Hz, resistive or inductive load.

For capacitive load, derate current by 20%.

MAXIMUM RATINGS (At $T_A=25^\circ\text{C}$ unless otherwise noted)

RATINGS	SYMBOL	SF11	SF12	SF13	SF14	SF15	SF16	UNITS
Maximum Recurrent Peak Reverse Voltage	V_{RRM}	50	100	150	200	300	400	Volts
Maximum RMS Voltage	V_{RMS}	35	70	105	140	210	280	Volts
Maximum DC Blocking Voltage	V_{DC}	50	100	150	200	300	400	Volts
Maximum Average Forward Rectified Current .375" (9.5mm) lead length @ $T_A=55^\circ\text{C}$	I_o	1.0						Amps
Peak Forward Surge Current, 8.3 ms single half sine-wave superimposed on rated load (JEDEC method)	I_{FSM}	30						Amps
Typical Junction Capacitance (Note 2)	C_J	15				10		pF
Operating and Storage Temperature Range	T_J T_{STG}	-65 to +150						$^\circ\text{C}$

ELECTRICAL CHARACTERISTICS (At $T_A=25^\circ\text{C}$ unless otherwise noted)

CHARACTERISTICS	SYMBOL	SF11	SF12	SF13	SF14	SF15	SF16	UNITS
Maximum Instantaneous Forward Voltage at 1.0A DC	V_F	0.95				1.25		Volts
Maximum DC Reverse Current at Rated DC Blocking Voltage	@ $T_A=25^\circ\text{C}$	5.0						μAmps
	@ $T_A=150^\circ\text{C}$	50						μAmps
Maximum Reverse Recovery Time (Note 1)	t_{rr}	35						nSec

Notes : 1. Test Condition: $I_F=0.5\text{A}$, $I_R=1.0\text{A}$, $I_{RR}=0.25\text{A}$

2. Measured at 1 MHz and applied reverse voltage of 4.0 volts

SF11 thru SF16

SUPER FAST RECTIFIER



**CHENG-YI
ELECTRONIC**

RATING AND CHARACTERISTICS CURVES SF11 THRU SF16

Fig. 1 - TEST CIRCUIT DIAGRAM AND REVERSE RECOVERY TIME CHARACTERISTIC

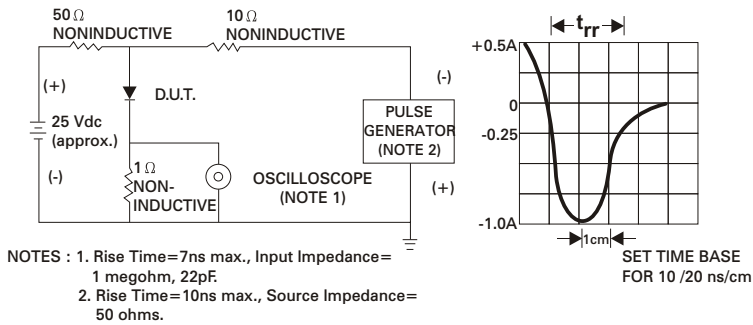

Fig. 2 - TYPICAL FORWARD CURRENT DERATING CURVE

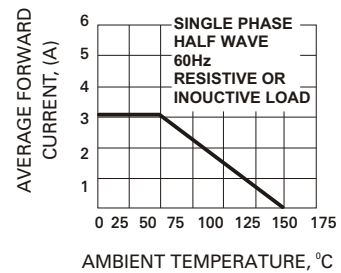

Fig. 3 - TYPICAL REVERSE CHARACTERISTICS

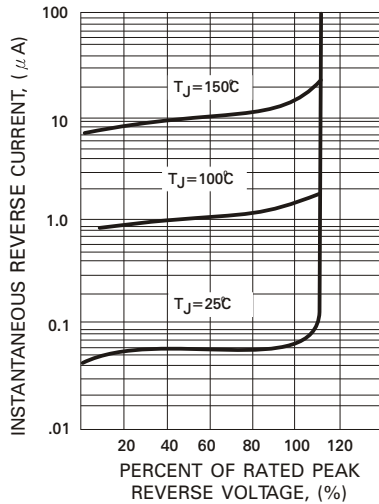

Fig. 4 - TYPICAL INSTANTANEOUS FORWARD CHARACTERISTICS

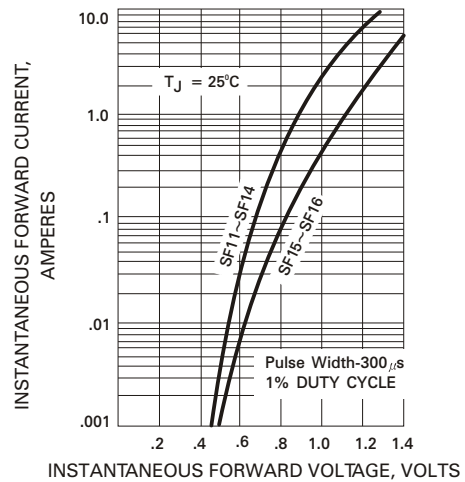

Fig. 5 - MAXIMUM NON-REPETITIVE FORWARD SURGE CURRENT

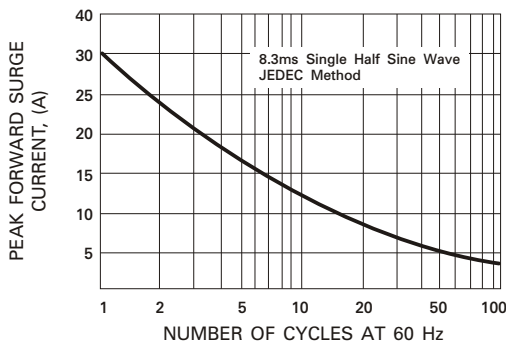

Fig. 6 - TYPICAL JUNCTION CAPACITANCE

